

ULTRAVOLT 10A AND 15A SERIES

PRECISION DC TO HIGH VOLTAGE DC CONVERTERS

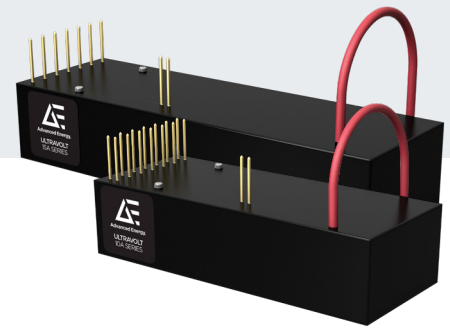

The UltraVolt® 10A and 15A series of regulated DC-to-DC converters provide general purpose high voltage power for a wide range of applications.

PRODUCT HIGHLIGHTS

- Regulated 0 to 10 kV or 0 to 15 kV DC high voltage output
- Single output: positive and negative polarity models
- Choice of 4, 15, or 30 W maximum output power
- 12 or 24 VDC input
- Maximum load capability down to 0 VDC
- Output ripple performance as low as 80 ppm (0.8 Vpp)
- Available temperature coefficients to 25 ppm/°C
- Ease of installation with PCB or chassis-mount options
- Simplified integration with available 0 to 5 VDC or 0 to 10 VDC interface
- Reliable modular design
- Factory-configured performance, control, and integration options
- UL/cUL recognized, CE mark (LVD and RoHS), IEC-60950-1

TYPICAL APPLICATIONS

- DC to high voltage DC bias supplies for general purpose uses
- High-potential testing
- PMT/APD detectors and optical spectrometers
- Electrostatics, electrophoresis, and electrospray
- Mass spectrometers

AT A GLANCE

Maximum Output Voltage

10 or 15 kV DC

Maximum Output Power

30 W

Type

Single Output

Ripple

To 80 ppm (0.8 Vpp)

Control Interface

Analog

Temperature Coefficient

To 25 ppm/°C

ULTRAVOLT 10A AND 15A SERIES

ELECTRICAL SPECIFICATIONS

Model		10A Series			15A Series		
High Voltage Output Range (Adjustable Regulated, Positive or Negative) ¹		0 to 10,000 VDC			0 to 15,000 VDC		
High Voltage Outputs		Single			Single		
Input Voltage (VDC, Nominal)		12 VDC	24 VDC		12 VDC	24 VDC	
Power Output (Watts, Nominal)		4 W	15 W	30 W	4 W	15 W	30 W
DC Input							
Vin (Input Voltage) Range	VDC (positive polarity only)	11 to 16	23 to 30		11 to 16	23 to 30	
Vin (Nominal)	VDC	12	24		12	24	
Iin (Input Current, Nominal)	A @ 100% HVout, 100% LOAD	< 0.5	< 1.5	< 1.6	< 0.5	< 1.5	< 1.6
	A @ 100% HVout, 0% LOAD	< 0.2	< 0.25	< 0.25	< 0.2	< 0.25	< 0.25
	A @ disable/standby state	< 0.03			< 0.03		
DC Output							
HVout (Output Voltage)	VDC (positive polarity models = +HVout)	0 to +10,000			0 to +15,000		
	VDC (negative polarity models = -HVout)	0 to -10,000			0 to -15,000		
Iout (Output Current)	mA (max) @ 0 to 100% HVout, Vin (nominal)	0.40	1.5	3.0	0.26	1.0	2.0
Pout (Output Power)	Watts (max)	4	15	30	4	15	30
Ripple ^{2,3}	ppm (standard configuration)	< 120	< 400	< 760	< 240	< 430	< 800
	ppm (with -F-M option)	< 80	< 340	< 720	< 210	< 280	< 730
	ppm (with -F-M-C option)	< 200	< 300	< 500	< 200	< 300	< 500
	Vpp (standard configuration)	< 1.2	< 4	< 7.6	< 3.6	< 6.5	< 12
	Vpp (with -F-M option)	< 0.8	< 3.4	< 7.2	< 3.2	< 4.2	< 11
	Vpp (with -F-M-C option)	< 2	< 3	< 5	< 3	< 4.5	< 7.5

¹ Standard product specifications shown unless noted. Custom configurations are available.

² Nominal ripple measured @ 100% HVout, 100% LOAD into 300 pf bypass capacitor. Valid for 10 to 100% HVout range.

³ ppm = parts per million @ 100% HVout. Vpp = VDC peak to peak @ 100% HVout.

Stability and Regulation

Stability	0.01% (100 ppm) @ 100% HVout (after 30 min warmup interval)
	0.02% (200 ppm) @ 100% HVout (per 8 h interval)
Line Regulation	0.01% (100 ppm) @ 100% HVout, 100% Pout, Vin (nominal)
Static Load Regulation	0.01% (100 ppm) @ 100% HVout, 0 to 100% LOAD
Temperature Coefficient	50 ppm/°C (standard configuration over operating temperature range)
	25 ppm/°C (with -25PPM option over operating temperature range)
Power-On Rise Time	< 150 msec @ 100% LOAD, < 50 msec @ 0% LOAD
	Contact factory for other options.

Environmental

Operating Temperature Range	-40 to 65°C (-40 to 149°F) case temperature
Storage	-55 to 105°C (-67 to 222°F) case temperature
Humidity	0 to 95% RH, non-condensing
Altitude	Sea level to 3000 m (10,000 ft)
	Sea level to high vacuum (with -P3 option)

Regulatory

Certifications	UL/cUL recognized, IEC-60950-1, CE mark (LVD and RoHS)
----------------	--

MECHANICAL SPECIFICATIONS

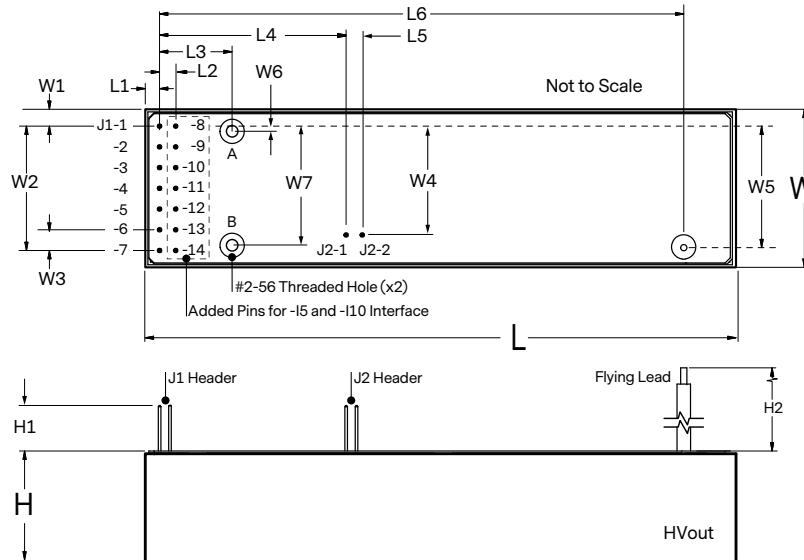

Dimensions		10A Series		15A Series	
Key	Description ^{1, 2, 3}	mm	in	mm	in
L	Overall Length	94.6	3.73	119.4	4.70
L1	Case Exterior to J1-1	3.2	0.13	3.2	0.13
L2	Centerline, J1-1 to J1-8	2.5	0.10	2.5	0.10
L3	Centerline, J1-1 to Hole A (Hole B)	17.8	0.70	17.8	0.70
L4	Centerline, J1-1 to J2-1	45.7	1.80	45.7	1.80
L5	Centerline, J2-1 to J2-2	2.5	0.10	2.5	0.10
L6	Centerline, J1-1 to Flying Lead	77.5	3.05	102.5	4.04
W	Overall Width	38.7	1.53	38.7	1.53
W1	Case Exterior to J1-1	3.8	0.15	3.8	0.15
W2	Centerline, J1-1 to J1-7	30.5	1.20	30.5	1.20
W3	Centerline, J1-6 to J1-7	5.1	0.20	5.1	0.20
W4	Centerline, J1-1 to J2-1	26.7	1.05	26.7	1.05
W5	Centerline, J1-1 to Flying Lead	29.7	1.17	29.7	1.17
W6	Centerline, J1-1 to Hole A	1.3	0.05	1.3	0.05
W7	Centerline, Hole A to Hole B	27.9	1.10	27.9	1.10
H	Case Height (Case Exterior to PCB, max)	25.4	1.00	25.4	1.00
H1	Base of PCB to J1/J2 Header Tip	11.2	0.44	11.2	0.44
H2	Length of Standard Flying Lead	470	18.5	470	18.5

Construction	
Standard Case	Injection-molded plastic (Diallyl Phthalate, DAP, per ASTM-D-5948)
Optional Case	RF-tight aluminum (-C option) (Anodized per MIL-A-8625 Type II)
Optional Shield	Six-sided Mu-Metal (-M option)
Labels	Static-dissipative polyester
Cooling	Natural convection and conduction
Encapsulation	Silicone-based RTV (contact factory for other options)
Pins	Gold-plated bronze

- 1 Approximate nominal dimensions and weights for standard configuration shown. Contact factory for -M, -C or -E case options.
- 2 Standard case (DAP plastic) tolerances are ± 1.27 mm (± 0.050 in). Pin-to-pin tolerances are ± 0.76 mm (± 0.015 in).
- 3 Refer to outline drawings and 3D models for detailed information.

Volumes and Weights	10A Series		15A Series	
	cm ³	in ³	cm ³	in ³
Volume (Module Body Only)	93.1	5.7	117.5	7.2
	g	oz	g	oz
Weight (Standard Configuration)	183	6.5	209	7.4

INTERFACE

The 10A and 15A series' standard interface permits voltage control and monitoring of both voltage and current output using analog DC signals whose range and polarity vary by model. The 10A model also offers UltraVolt's optional -I5 or -I10 interface which provides simplified control and monitoring of both voltage and current using 0 to 5 VDC or 0 to 10 VDC full-scale analog signals.

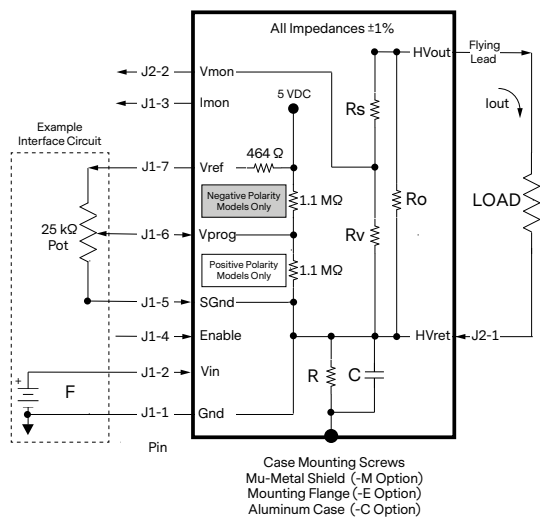

Standard Interface			
Pin	Label	Type	Description
J1-1	Gnd	Ground	DC Input Power Ground
J1-2	Vin	Input	DC Input Power
J1-3	Imon	Output	Monitor HVout Current Level
J1-4	Enable	Input	Enable HVout ¹
J1-5	SGnd	Ground	Signal Ground
J1-6	Vprog	Input	Set HVout Voltage Level
J1-7	Vref	Output	Control Signal Reference ²
J2-1	HVret	Ground	High Voltage Return ⁹
J2-2	Vmon	Output	Monitor HVout Voltage Level
Flying Lead	HVout	Output	High Voltage Output

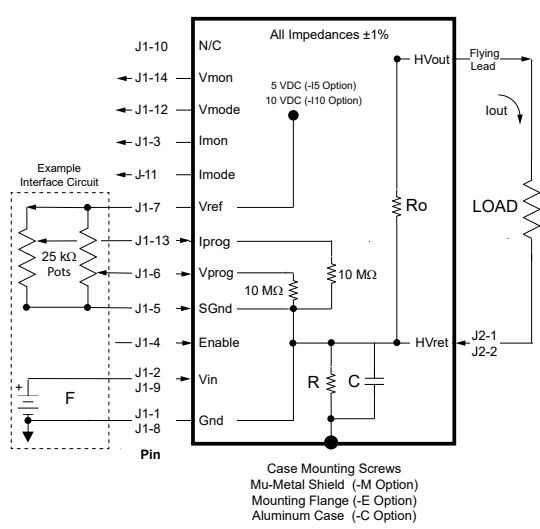

-I5 and -I10 Interface (Optional)			
Pin	Label	Type	Description
J1-1	Gnd	Ground	DC Input Power Ground
J1-2	Vin	Input	DC Input Power
J1-3	Imon	Output	Monitor HVout Current Level ^{3, 8}
J1-4	Enable	Input	Enable HVout ⁴
J1-5	SGnd	Ground	Signal Ground
J1-6	Vprog	Input	Set HVout Voltage Level
J1-7	Vref	Output	Control Reference Signal ^{5, 6}
J1-8	Gnd	Ground	DC Input Power Ground
J1-9	Vin	Input	DC Input Power
J1-10	N/C		No Connection
J1-11	Imode	Output	Current Mode Indicator ⁷
J1-12	Vmode	Output	Voltage Mode Indicator ⁷
J1-13	Iprog	Input	Set HVout Current Level
J1-14	Vmon	Output	Monitor HVout Voltage Level ^{3, 8}
J2-1	HVret	Ground	High Voltage Return ⁹
J2-2	HVret	Ground	High Voltage Return ⁹
Flying Lead	HVout	Output	High Voltage Output

¹ Signal inputs: LOW < 0.5 VDC, HIGH > 2.4 VDC (Default or N/C = ENABLED = HIGH)
² 5 VDC ±2% through 464 Ω impedance load
³ Can source an output impedance load > 10 kΩ
⁴ Signal input: LOW < 0.5 VDC, HIGH > 2.4 VDC (Default or N/C = DISABLED = LOW)
⁵ -I5 interface: 5 VDC ±0.1% @ 5 mA (nominal at case temperature = 25°C, 77°F)
⁶ -I10 interface: 10 VDC ±0.1% @ 5 mA (nominal at case temperature = 25°C, 77°F)

⁷ LOW = Mode ENABLED (open drain) will sink up to 30 mA.
⁸ Voltage/current monitors will source/sink to 2 mA.
⁹ For proper operation and safety, always route HVret signal through HVret connection.

INTERFACE CONTROL PARAMETERS

MODEL	10A Series			15A Series		
High Voltage Output Range	0 to 10,000 VDC			0 to 15,000 VDC		
Input Voltage (VDC, Nominal)	12 VDC	24 VDC		12 VDC	24 VDC	
Power Output (Watts, Nominal)	4 W	15 W	30 W	4 W	15 W	30 W
Standard Interface (Monitor/Control Voltage, Monitor Current)						
Scale Factors ^{1, 2, 3}	SVm (V/V) where HVout Monitor = SVm x Vmon			1000		
Positive Polarity Models	SVp (V/V) where HVout Control = SVp x Vprog			2155		
Negative Polarity Models	SVp (V/V) where HVout Control = SVp x (5 - Vprog)			-2155		
	Slm (mA/V) where Iout Monitor = Slm x Imon			0.167	0.184	0.381
	Slp (mA/V) where Iout Control = Slp x Iprog			N/A		
Impedances ⁴	Ro (HVout impedance, ±1%)			500 MΩ		
	Rs (Vmon upper tap impedance, ±1%)			500 MΩ		
	Rv (Vmon lower tap impedance, ±1%)			523 kΩ		
-I5 Interface (0 to 5 VDC, Monitor/Control Both Voltage and Current)						
Scale Factors ^{5, 6, 8, 9}	SVm (V/V) where HVout Monitor = SVm x Vmon			2000		
	SVp (V/V) where HVout Control = SVp x Vprog			2000		
	Slm (mA/V) where Iout Monitor = Slm x Imon			0.08	0.30	0.60
	Slp (mA/V) where Iout Control = Slp x Iprog			0.08	0.30	0.60
Impedances ⁴	Ro (HVout impedance, ±1%)			375 MΩ		
-I10 Interface (0 to 10 VDC, Monitor/Control Both Voltage and Current)						
Scale Factors ^{5, 7, 8, 9}	SVm (V/V) where HVout Monitor = SVm x Vmon			2000		
	SVp (V/V) where HVout Control = SVp x Vprog			2000		
	Slm (mA/V) where Iout Monitor = Slm x Imon			0.04	0.15	0.3
	Slp (mA/V) where Iout Control = Slp x Iprog			0.04	0.15	0.3
Impedances ⁴	Ro (HVout impedance, ±1%)			375 MΩ		
Other Interface Values						
Impedances ⁴	R (standard case via mounting screws, ±1%)			232 kΩ		232 kΩ
	R (standard case with -I5 /-I10 option, ±1%)			100 kΩ		N/A
	R (with -M option, ±1%)			232 kΩ	0 Ω	232 kΩ 0 Ω
	R (with -E option, ±1%)			232 kΩ		232 kΩ
	R (with -C option, ±1%)			232 kΩ		232 kΩ
	R (with -M-E option, ±1%)			0 Ω		0 Ω
	R (with -M-C option, ±1%)			0 Ω		0 Ω
Capacitance ⁴	C (@ 50 VDC ±10%, 1/8 W, max)			0.01 μF	0 μF	0.01 μF 0 μF
Input Voltage Protection	F (fuse or other protection recommended)			See note 10		See note 10

1 For positive polarity models, Vprog varies from 0 to 4.64 VDC. For negative polarity models, Vprog varies inversely from 5 to 0.36 VDC.

2 Slm factor is ±2% @ 100% LOAD, 100% HVout. Valid for 10 to 100% Iout range.

3 SVm factor is ±2% assuming a 10 MΩ measurement impedance. Valid from 10 to 100% HVout.

4 See interface schematics for definition.

5 For details on -I5/-I10 interfacing, see technical note TN-I5-I10-1.

6 For the -I5 interface, Imon, Iprog, Vmon, and Vprog input/output signals vary from 0 to 5 VDC (full-scale).

7 For the -I10 interface, Imon, Iprog, Vmon, and Vprog input/output signals vary from 0 to 10 VDC (full-scale).

8 SVm factor is ±1% for both -I5 and -I10 Interfaces. SVp factor is also ±1% and is valid from 10 to 100% HVout.

9 Slm factor is ±1% for both -I5 and -I10 Interfaces. Slp factor is also ±1% and is valid from 10 to 100% Iout.

10 For details on fuse selection, see technical note TN-23.

ULTRAVOLT 10A AND 15A SERIES

STANDARD OPTIONS

Both the 10A and 15A series can be configured with standard options that can adapt its performance and packaging for many application requirements. Customized models to meet specialized performance, packaging, or environmental needs are also available.

Featured Options	
-I5	Upgrades interface to provide more precise control and monitoring of both HVout and Iout using 0 to 5 VDC (full-scale) analog signals. Also adds Iout control and voltage/current mode indication capability not available on the standard interface. Cannot be ordered with the -I10 option. Available only on 10A series models.
-I10	Upgrades interface to provide more precise control and monitoring of both HVout and Iout using 0 to 10 VDC (full-scale) analog signals. Also adds Iout control and voltage/current mode indication capability not available on the standard interface. Cannot be ordered with the -I5 option. Available only on 10A series models with 24 VDC input.
-F	Reduces high voltage ripple when used together with the Mu-Metal shield and a user-supplied external capacitive load. Available only with the the Mu-Metal shield (-M option).
-M	Adds a Mu-Metal shield to reduce the effects of external RF noise sources. Installed on six sides, this shield option is available on both standard plastic (DAP) and optional aluminum (-C option) cases.
-E	Eared mounting flange that permits the standard plastic (DAP) case to be chassis-mounted.
-C	Aluminum alloy case with integrated mounting flange that provides both added RF and environmental protection.
-AP	Adds non-conductive braiding to the standard HVout flying lead for increased durability. Terminating connector is user-supplied. Not available with the -WS option.
-WS	Replaces the standard HVout flying lead with a 470 mm long shielded coaxial cable for added RF protection. Terminating connector is user-supplied. Not available with the -AP option.
-25PPM	Upgrades module temperature coefficient rating from 50 ppm/°C to 25 ppm/°C for enhanced high voltage output stability over standard operating temperature ranges.
-H	Heatsink option

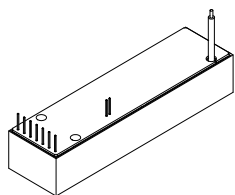

Standard Interface

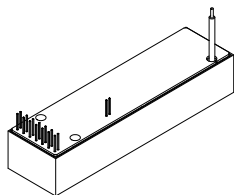

-I5 and -I10 Interface

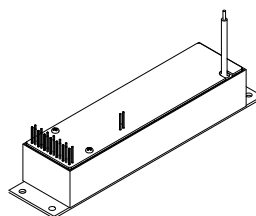

-E Option (Eared Mounting Plate)

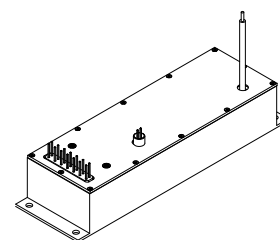

-C Option (Aluminum Case)

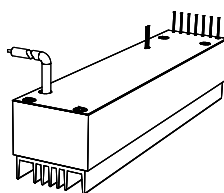

-H Heatsink

ORDERING INFORMATION

Standard Part		STANDARD CONFIGURATION										OPTIONS							Other Options
		Electrical Performance					Standard Features		Interfaces		Ripple	Mechanical			Temp				
		Number of High Voltage Outputs	High Voltage Output Range (HVout VDC, Adjustable)	Input Voltage (Vin, VDC)	High Voltage Output Polarity	High Voltage Output Power (Pout, Watts)	Standard Interface	Plastic Case (DAP)	Standard HVout Lead (No Connector, 470 mm)	50 ppm/°C Temperature Coefficient		Select One	Select One	Select One		Select One			
10A	10A12-P4	1	0 to +10,000	12	Pos	4	Included		-15		-F	-M	-E	-C	-H	-AP	-WS	-25PPM	
	10A12-N4	1	0 to -10,000	12	Neg	4	Included		-15		-F	-M	-E	-C	-H	-AP	-WS	-25PPM	
	10A24-J15	1	0 to +10,000	24	Pos	15	Included		-15	-110	-F	-M	-E	-C	-H	-AP	-WS	-25PPM	
	10A24-N15	1	0 to -10,000	24	Neg	15	Included		-15	-110	-F	-M	-E	-C	-H	-AP	-WS	-25PPM	
	10A24-P30	1	0 to +10,000	24	Pos	30	Included		-15	-110	-F	-M	-E	-C	-H	-AP	-WS	-25PPM	
	10A24-N30	1	0 to -10,000	24	Neg	30	Included		-15	-110	-F	-M	-E	-C	-H	-AP	-WS	-25PPM	
15A	15A12-P4	1	0 to +15,000	12	Pos	4	Included				-F	-M	-E	-C	-H	-AP	-WS	-25PPM	
	15A12-N4	1	0 to -15,000	12	Neg	4	Included				-F	-M	-E	-C	-H	-AP	-WS	-25PPM	
	15A24-J15	1	0 to +15,000	24	Pos	15	Included				-F	-M	-E	-C	-H	-AP	-WS	-25PPM	
	15A24-N15	1	0 to -15,000	24	Neg	15	Included				-F	-M	-E	-C	-H	-AP	-WS	-25PPM	
	15A24-P30	1	0 to +15,000	24	Pos	30	Included				-F	-M	-E	-C	-H	-AP	-WS	-25PPM	
	15A24-N30	1	0 to -15,000	24	Neg	30	Included				-F	-M	-E	-C	-H	-AP	-WS	-25PPM	

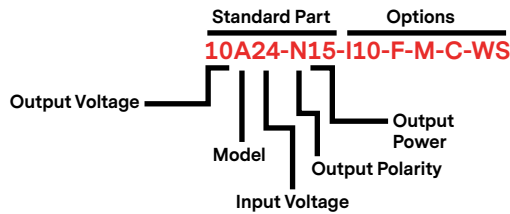



For international contact information,
visit advanced-energy.com.

uv-ca@aei.com
+1.970.221.0108

ABOUT ADVANCED ENERGY

Since 1981, UltraVolt® — now part of the Advanced Energy (AE) family — has perfected how power performs for its customers. For both end users and OEMs, AE's comprehensive portfolio of standard and custom high voltage components precisely match system specifications to deliver unparalleled energy, quality, and performance. Through close customer collaboration, design expertise, application insight, and world-class support, AE creates successful partnerships and enables customers to push the boundaries of innovation and stay ahead of evolving market needs.

PRECISION | POWER | PERFORMANCE



CAUTION:
High Voltage

Read and understand all documentation before you install, operate, or maintain Advanced Energy high voltage power supplies. Follow all safety instructions and precautions to protect against property damage and serious or possibly fatal bodily injury. Never defeat safety interlocks or grounds.

Specifications are subject to change without notice. Not responsible for errors or omissions. ©2019 Advanced Energy Industries, Inc. All rights reserved. Advanced Energy®, AE®, and UltraVolt® are U.S. trademarks of Advanced Energy Industries, Inc.

