

■ Features

- Special material and design for high working voltage require.

■ Applications

- Back light inverter
- Measurement instrument
- Medical or Military equipment
- Power supply
- Automotive industry
- Laser printer

■ Description

The resistors are constructed on a high grade ceramic body (aluminum oxide). Internal metal electrodes are added at each end and connected by a resistive paste which is applied to the top surface of the substrate. The composition of the paste is adjusted to give the approximate resistance required and the value is trimmed to within tolerance by laser cutting of this resistive layer.

The resistive layer is covered with a protective coating and printed with the resistance value. Finally the two external end termination are added. For ease of soldering the outer of these end termination is a pure tin metal.

■ Configuration / Dimensions

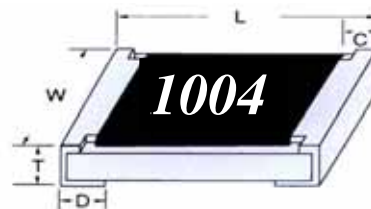
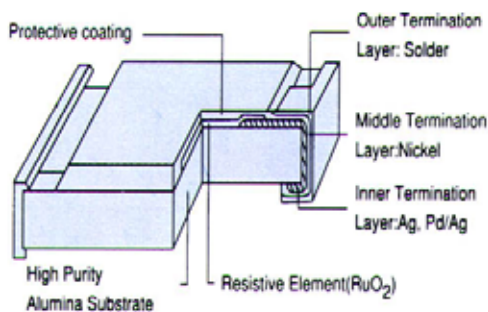

Size	L	W	C	D	T
1206	3.10±0.15	1.60±0.15	0.50±0.25	0.50±0.25	0.55±0.10
2010	5.00±0.20	2.50±0.20	0.60±0.25	0.60±0.25	0.60±0.10
2512	6.30±0.20	3.10±0.20	0.60±0.25	0.60±0.25	0.60±0.15

(unit : mm)

■ Power Derating Curve

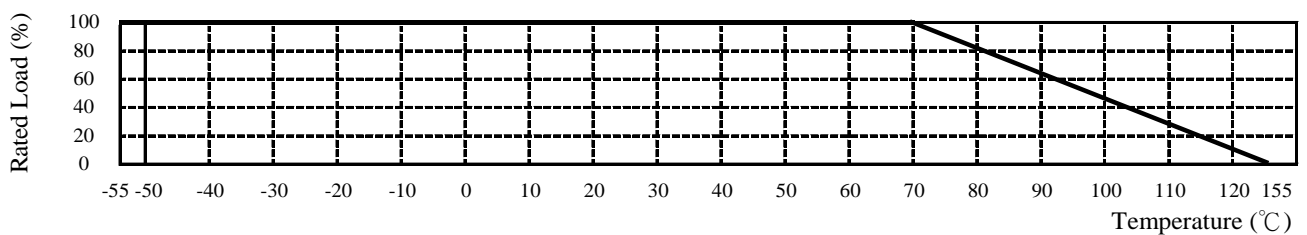

For resistors operated in ambient temperatures over 70°C, power rating shall be derated in accordance with the curve above.

■ Rating

. HIGH VOLTAGE POWER CHIP RESISTORS

Type	Size	Power Rating at 70	Max. Working Voltage	Max. Overload Voltage	Resistance Tolerance	Temperature Coefficient (TCR; ppm/)	Resistance Range		Standard Resistance Values
							Min.	Max.	
FVF06	1206	1/4W	800V	1600V	±5%(J)	±200	100K	100M	E-24
FVF20	2010	1/2W	1500V	3000V					
FVF25	2512	1W	2000V	4000V					

■ Dissipation

The rated power that the resistor can dissipate depends on the operating temperature

$$P_{\text{rated}} = (\text{Working Voltage})^2 / \text{resistance value}$$

■ Part Number

<u>FVF</u>	<u>20</u>	<u>J</u>	<u>P</u>	<u>-</u>	<u>106</u>
Type	Size	Tolerance	Packing		GM
FVF	06 : 1206 20 : 2010 25 : 2512	J : ± 5%	T : Plastic tape - 5Kpcs V : Plastic tape - 10Kpcs W : Plastic tape - 20Kpcs P : Plastic tape - 4Kpcs X : Plastic tape - 8Kpcs Y : Plastic tape - 16Kpcs		

■ Resistance Marking

E - 24 SERIES



3 digit marking for ±1% and ±5% 1206, 2010, 2512

examples: **106** $10 \times 10^6 = 10M$

Taping specification

Ability

Peel force is 0.2N to 1.0N at peel off speed of 300 mm/minute, and doesn't have flash and tear under the following test method.

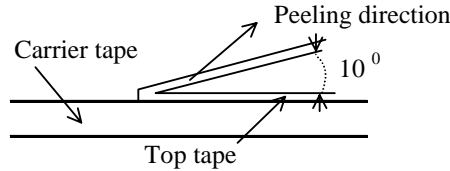

Minimum bending radius

When carrier tape is bent by min. bending radius(15mm) only one time, no deflection of chip and no break of carrier tape.

Temperature test of top tape

Top tape doesn't peel after 120 hours exposure at 60°C, 90-95%R.H.

Taping package condition

Resistance side is facing up.

Chip resistor is free, not sticking to top tape and bottom tape.

Chip resistor is easy to take out from carrier tape and chip hole have no mechanical damage.

Tape And Reel Package

Taping specs are according to EIA RS-481

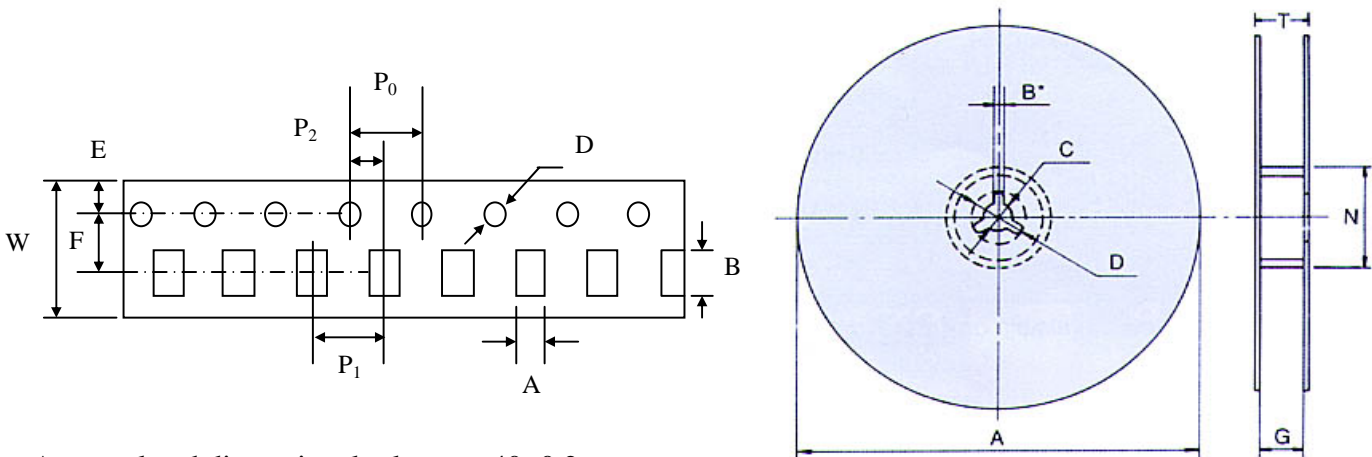

Accumulated dimensional tolerance 40±0.2mm

Tape :

Size	A	B	W	F	E	P1	P2	P0	D
1206	2.00±0.20	3.60±0.20	8.00±0.30	3.50±0.05	1.75±0.10	4.00±0.10	2.00±0.05	4.00±0.10	1.50+0.10/-0
2010	2.80±0.20	5.50±0.20	12.00±0.30	5.50±0.05	1.75±0.10	4.00±0.10	2.00±0.05	4.00±0.10	1.50+0.10/-0
2512	3.50±0.20	6.70±0.20	12.00±0.30	5.50±0.05	1.75±0.10	4.00±0.10	2.00±0.05	4.00±0.10	1.50+0.10/-0

Reel :

Size	Packaging Q'ty	A	N	C	D	B	G	T
1206	5Kpcs / Reel	178.0±2.0	60±0.5	13.0±0.5	20min	2.00±0.5	10.0±1.5	14.9 max.
2010	4Kpcs / Reel	178.0±2.0	60±0.5	13.0±0.5	20min	2.00±0.5	13.8±1.5	16.7 max.
2512								

(unit : mm)

■ Specification And Test Methods

ITEM	SPECIFICATION	TEST METHOD
DC Resistance	J: $\pm 5\%$	IEC 60115-1 / JIS C 5201-1, Clause 4.5 Measure the resistance value.
Short time Overload	J: $\Delta R \leq \pm(1\% + 0.1\Omega)$ No mechanical damage	IEC 60115-1 / JIS C 5201-1, Clause 4.13 2×Rated voltage or Max. Overload Voltage for 5 sec. measure resistance after 30 minutes
Solderability	Over 95% of termination must be covered with (Sn+Ag+Cu)	IEC 60115-1/ JIS C5201-1, Clause 4.17 After immersing flux, dip in the $235\pm 2^\circ\text{C}$ molten solder bath for 2 ± 0.5 sec.
Resistance to Solder Heat	J: $\Delta R \leq \pm(1\% + 0.1\Omega)$ No mechanical damage	IEC 60115-1/ JIS C5201-1, Clause 4.18 With $260\pm 5^\circ\text{C}$ for 10 ± 1 sec.
Temperature Coefficient of Resistance (TCR)	J: $\pm 200 \text{ ppm}/^\circ\text{C}$	IEC 60115-1/ JIS C5201-1, Clause 4.8 $\text{TCR}(\text{ppm}/^\circ\text{C}) = \frac{R_2 - R_1}{R_1} \times \frac{1}{T_2 - T_1} \times 10^6$ Test temperature: $25^\circ\text{C} \rightarrow -55^\circ\text{C}$ $25^\circ\text{C} \rightarrow 125^\circ\text{C}$ T1: 25°C T2: Test temperature R1: Resistance at reference temperature (T1) R2: Resistance at test temperature (T2)
Voltage Coefficient of Resistance (VCR)	$\pm 300 \text{ ppm}/\text{V}$	JIS C 5202 4.1 Measuring Voltage 10V/100V
Load Life Humidity	J: $\Delta R \leq \pm(5\% + 0.1\Omega)$	IEC 60115-1/ JIS C5201-1, Clause 4.24 Maintain the temperature of the resistor at $40\pm 2^\circ\text{C}$ and 90~95% RH with the rated voltage applied. Cycle ON for 1.5 hours and OFF for 0.5 hour for 1000+48/-0 hours. After 1~4 hour, measure the resistance value.
Load Life	J: $\Delta R \leq \pm(5\% + 0.1\Omega)$	IEC 60115-1/ JIS C5201-1, Clause 4.25 Permanent resistance change after 1000+48/-0 hours (1.5 hours ON, 0.5 hour OFF) at RCWV or Max. Keep the resistor at $70\pm 2^\circ\text{C}$ ambient
Temperature Cycle	J: $\Delta R \leq \pm(1\% + 0.05\Omega)$ No mechanical damage	IEC 60115-1/ JIS C5201-1, Clause 4.19 Repeat 5 cycles as follows -55°C (30 min.) + 25°C (2~3 min.) $+155^\circ\text{C}$ (30 min.) + 25°C (2~3 min.)
Insulation Resistance	Between termination and coating must be over $1000\text{M}\Omega$	IEC 60115-1/ JIS C5201-1, Clause 4.6 Test voltage: $100\pm 15\text{V}$
Bending Strength	J: $\Delta R \leq \pm(1\% + 0.05\Omega)$ No mechanical damage	IEC 60115-1/ JIS C5201-1, Clause 4.33 Resistance change after bended on the 90mm PCB. Bend: 2mm for 1206 ,2010,2512

All product specification and data are subject to change without notice