

FTF series Lead Free Trimmable Chip Resistors



■ Features

- Small size and lightweight with size range per int'l standard
- Highly stable in auto-placement surface mounting application
- Available for fine tuning of the resistance value to obtain optimal circuit signals.

■ Applications

- Tuner
- Camcorder
- Photo sensor
- Mobile phone
- Portable audio
- Portable measuring equipment

■ Configuration

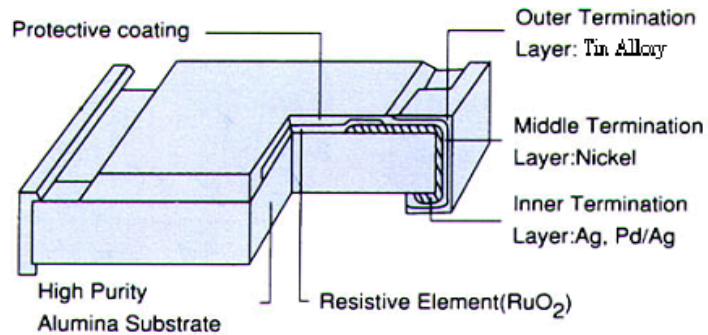

■ Dimensions

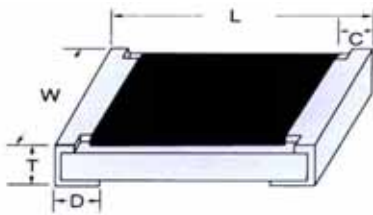

Size	L	W	C	D	T
0603	1.60±0.10	0.80±0.10	0.30±0.20	0.30±0.20	0.45±0.10
0805	2.00±0.15	1.20±0.15	0.40±0.20	0.40±0.20	0.50±0.10
1206	3.10±0.15	1.60±0.15	0.50±0.25	0.50±0.25	0.55±0.10
2010	5.00±0.20	2.50±0.20	0.60±0.25	0.60±0.25	0.60±0.10
2512	6.30±0.20	3.10±0.20	0.60±0.25	0.60±0.25	0.60±0.15

(unit: mm)

■ Power Derating Curve

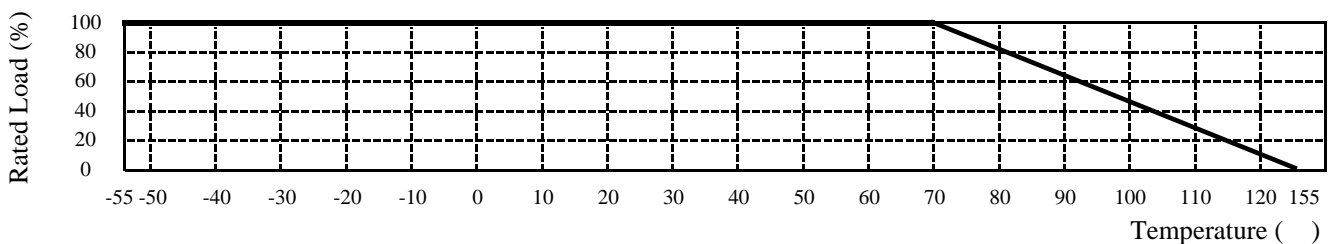

For resistors operated in ambient temperatures over 7°C, power rating shall be derated in accordance with the curve above

FTF series Lead Free Trimmable Chip Resistors



Resistance rising rate

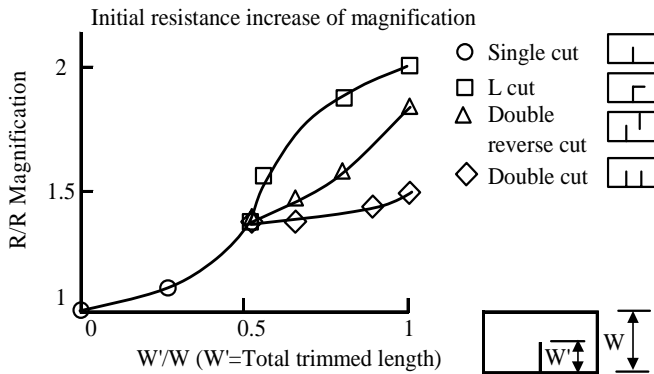

Trimming shall be performed by laser. The resistance rising limits the initial resistance value up to 2 times and the differences are depending on trimming patterns as shown at the left.

Rating

Type	Size	Power Rating at 70	Max. RCWV	Max. Overload Voltage	Resistance Tolerance (%)	Temperature Coefficient (TCR; ppm/°C)	Resistance Range		Standard Resistance Values
							Min.	Max.	
FTF03	0603	1/10W	50V	100V	0 ~ -30%(X) 0 ~ -20%(Y) 0 ~ -10%(Z)	±100	10	1M	E-24
FTF05	0805	1/8W	150V	300V					
FTF06	1206	1/4W	200V	400V					
FTF20	2010	1/2W	200V	400V					
FTF25	2512	1W	200V	400V					

Part Number

FTF	05	X	T	-	103
Type	Size	Tolerance	Packing		GM
FTF	03 : 0603 05 : 0805 06 : 1206 20 : 2010 25 : 2512	X : 0% ~ -30% Y : 0% ~ -20% Z : 0% ~ -10%	T : Paper tape - 5Kpcs V : Paper tape - 10Kpcs W : Paper tape - 20Kpcs P : Plastic tape - 4Kpcs X : Plastic tape - 8Kpcs Y : Plastic tape - 16Kpcs		examples: 103 10×10 ³ = 10K

Standard resistance value

E3	10				22				47									
E6	10		15		22		33		47		68							
E12	10	12	15	18	22	27	33	39	47	56	68	82						
E24	10	11	12	13	15	16	18	20	22	24	27	30	33	36	39	43	47	
	51	56	62	68	75	82	91											

SPECIFICATION

Tape And Reel Package

- Taping specs are according to EIA RS-481

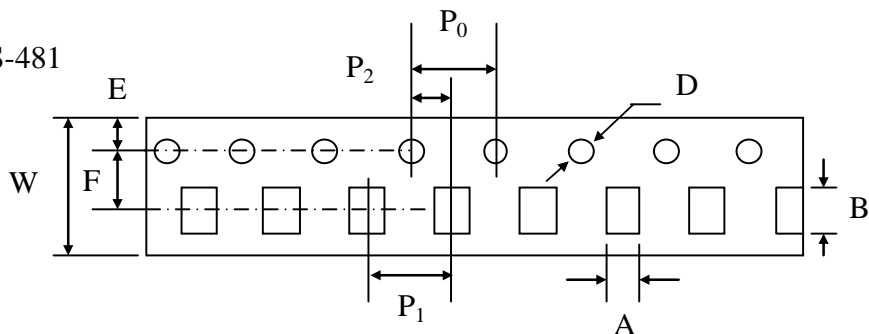

Accumulated dimensional tolerance $40 \pm 0.2 \text{mm}$

Size	A	B	W	F	E	P1	P2	P0	D
0603	1.10 ± 0.20	1.90 ± 0.20	8.00 ± 0.30	3.50 ± 0.05	1.75 ± 0.10	4.00 ± 0.10	2.00 ± 0.05	4.00 ± 0.10	$1.50 + 0.10 / -0$
0805	1.65 ± 0.20	2.40 ± 0.20	8.00 ± 0.30	3.50 ± 0.05	1.75 ± 0.10	4.00 ± 0.10	2.00 ± 0.05	4.00 ± 0.10	$1.50 + 0.10 / -0$
1206	2.00 ± 0.20	3.60 ± 0.20	8.00 ± 0.30	3.50 ± 0.05	1.75 ± 0.10	4.00 ± 0.10	2.00 ± 0.05	4.00 ± 0.10	$1.50 + 0.10 / -0$
2010	2.80 ± 0.20	5.50 ± 0.20	12.00 ± 0.30	5.50 ± 0.05	1.75 ± 0.10	4.00 ± 0.10	2.00 ± 0.05	4.00 ± 0.10	$1.50 + 0.10 / -0$
2512	3.50 ± 0.20	6.70 ± 0.20	12.00 ± 0.30	5.50 ± 0.05	1.75 ± 0.10	4.00 ± 0.10	2.00 ± 0.05	4.00 ± 0.10	$1.50 + 0.10 / -0$

(unit: mm)

- Reel Package

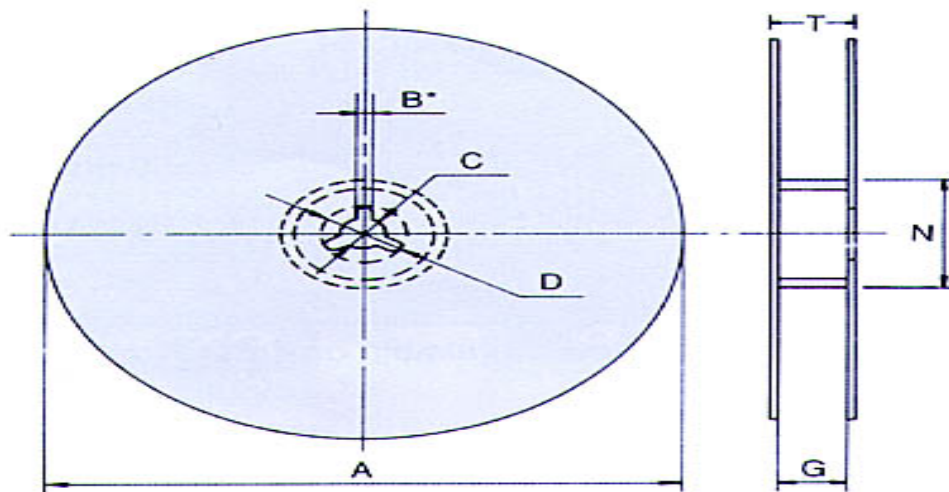

Size	Packaging Q'ty	A	N	C	D	B	G	T
0603	5Kpcs / Reel	178.0 ± 2.0	60.0 ± 0.5	13.0 ± 0.5	20min	2.0 ± 0.5	10.0 ± 1.5	14.9 max.
0805	10Kpcs / Reel	254.0 ± 2.0	100.0 ± 1.0	13.5 ± 0.5	20min	2.0 ± 0.5	10.0 ± 1.5	14.9 max.
1206	20Kpcs / Reel	330.0 ± 2.0	100.0 ± 1.0	13.5 ± 0.5	20min	2.0 ± 0.5	10.0 ± 1.5	14.9 max.
2010 2512	4Kpcs / Reel	178.0 ± 2.0	60.0 ± 0.5	13.0 ± 0.5	20min	2.0 ± 0.5	13.8 ± 1.5	16.7 max.
	8Kpcs / Reel	254.0 ± 2.0	100.0 ± 1.0	13.5 ± 0.5	20min	2.0 ± 0.5	13.8 ± 1.5	20.0 max.
	16Kpcs / Reel	330.0 ± 2.0	100.0 ± 1.0	13.5 ± 0.5	20min	2.0 ± 0.5	13.8 ± 1.5	20.0 max.

(unit: mm)

Soldering Temperature Curve

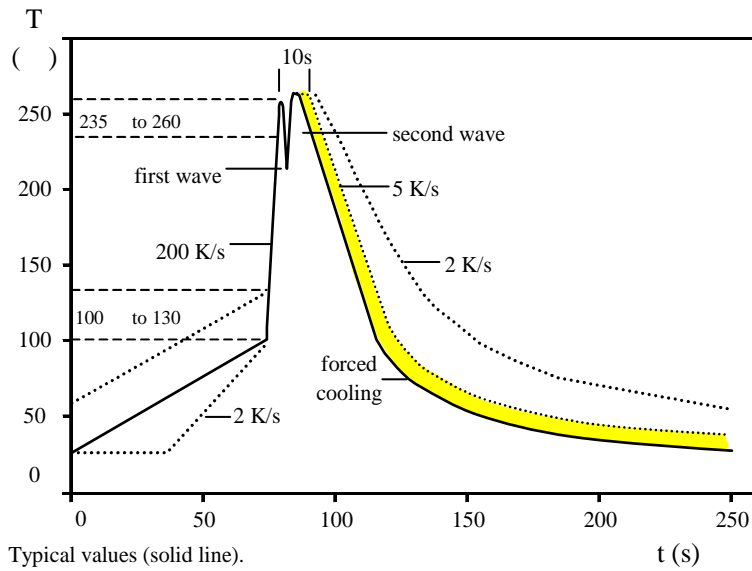

Typical values (solid line).
Process limits (dotted line). WAVE soldering.

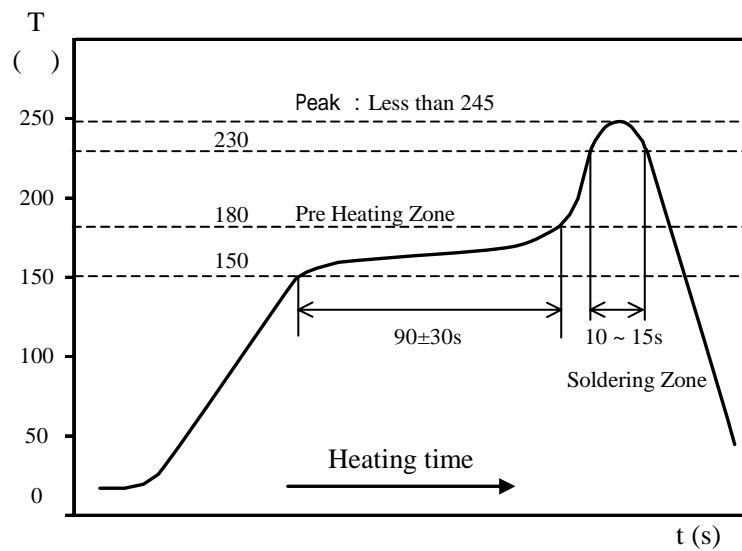

IR Reflow Soldering

SPECIFICATION

■ Specification And Test Methods

ITEM	SPECIFICATION	TEST METHOD
DC Resistance	X : 0 ~ -30% , Y : 0 ~ -20% , Z : 0 ~ -10%	IEC 60115-1 / JIS C 5201-1 , Clause 4.5 Measure the resistance value.
Short time Overload	$\Delta R \leq \pm (2\% + 0.1 \Omega)$	IEC 60115-1 / JIS C 5201-1 , Clause 4.13 2.5×Rated voltage or Max. Overload Voltage for 5 sec. measure resistance after 30 minutes
Solderability	Over 95% of termination must be covered with(Sn+Ag+Cu)	IEC 60115-1 / JIS C 5201-1 , Clause 4.17 After immersing flux, dip in the 235±5°C molten solder bath for 2±0.5 sec.
Resistance to Solder Heat	$\Delta R \leq \pm (1\% + 0.1 \Omega)$ No mechanical damage	IEC 60115-1 / JIS C 5201-1 , Clause 4.18 With 260±5°C for 10±1 sec.
Temperature Coefficient of Resistance (TCR)	±100 ppm/	IEC 60115-1 / JIS C 5201-1 , Clause 4.8 Test temperature : 25°C (T1) → -55°C (T2) 25°C (T1) → +155°C (T2) $TCR (ppm/^\circ C) = \frac{R2-R1}{R1} \times \frac{1}{T2-T1} \times 10^6$ T1: 25°C T2: Test temperature R1: Resistance at reference temperature (T1) R2: Resistance at test temperature (T2)
Load Life Humidity	$\Delta R \leq \pm (3\% + 0.1 \Omega)$	IEC 60115-1 / JIS C 5201-1 , Clause 4.24 Maintain the temperature of the resistor at 40±2°C and 90~95% R.H. with the rated voltage applied. Cycle ON for 1.5 hours and OFF for 0.5 hour for 1000+48/-0 hours. After 1~4 hour, measure the resistance value.
Load Life	$R \pm (3\% + 0.1 \Omega)$	IEC 60115-1 / JIS C 5201-1 , Clause 4.25 Permanent resistance change after 1000+48/-0 hours (1.5 hours ON , 0.5 hour OFF) at RCWV or Max. Keep the resistor at 70±2°C ambient
Temperature Cycle	$\Delta R \leq \pm (1\% + 0.1 \Omega)$ No mechanical damage	IEC 60115-1 / JIS C 5201-1 , Clause 4.19 Repeat 5 cycles as follows -55°C (30 min.) + 25°C (2~3 min.) +155°C (30 min.) + 25°C (2~3 min.)
Insulation Resistance	Between termination and coating must be over 1000MΩ	IEC 60115-1 / JIS C 5201-1 , Clause 4.6 Test voltage: 100±15V
Bending Strength	$R \pm (1\% + 0.1 \Omega)$ No mechanical damage	IEC 60115-1 / JIS C 5201-1 , Clause 4.33 Resistance change after bended on the 90mm PCB. Bend: 3mm for 0603 、0805 , 2mm for 1206 、2010 、2512

All product specification and data are subject to change without notice