

**FPF** series

Thick-Film Type

High-Power Low Resistance Lead Free Chip Resistors



PDC

1. SCOPE.....	2
Purpose.....	2
Configuration.....	2
Part Number.....	2
2. PERFORMANCE CHARACTERISTICS.....	3
2.1 Power Derating Curve by Ambient Temperature.....	3
2.2 Mechanical Dimensions.....	3
2.3 Recommended Solder-Pad Dimensions.....	3
3. SPECIFICATION.....	4
3.1 Electrical Characteristic.....	4
3.2 Reliability Performance.....	4~5
4. PACKAGING.....	5
Peel Strength of Top Cover Tape.....	5
Tape Packaging Dimensions.....	6
Reel Dimensions.....	6



1. SCOPE

1.1 Purpose

Fixed Thick-Film High-Power Chip Resistors, Rated Power up to 2W, used in Consumer Electronics, SMPS, M/B, electronic equipment.

1.2 Configuration

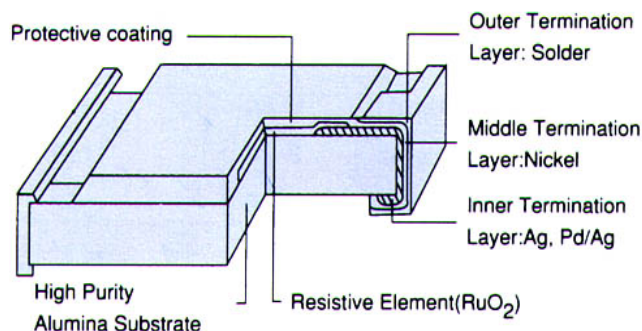

Part Number:

<b>FPF</b>	<b>25</b>	<b>F</b>	<b>P</b>	<b>-</b>	<b>R100</b>
Type	Size	Tolerance	Packing		GM
FPF	03 : 0603	F : ± 1%	T : Paper tape – 5 Kpcs		
	05 : 0805	J : ± 5%	V : Paper tape – 10 Kpcs		
	06 : 1206		W : Paper tape – 20 Kpcs		
	20 : 2010		P : Plastic tape – 4 Kpcs		
	25 : 2512		X : Plastic tape – 8 Kpcs		
			Y : Plastic tape – 16Kpcs		

Resistance Marking

**E - 24 Series**

4 digit marking for ±1%,±5% 0805 , 1206 , 2010 , 2512



examples : R100 = 100m

R050 = 50m



3 digit marking for ±1%,±5% 0603 ( 100m ~910m )

examples : R10 = 100m



3 digit marking for ±1%,±5% 0603 ( 47m ~91m )

examples : 47M = 47m



2. PERFORMANNCE CHARCTERISTICS

Power Derating Curve by Ambient Temperature

Rated Load (%)

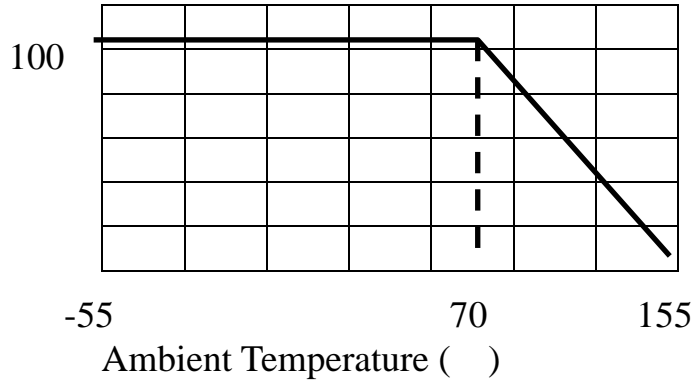

Mechanical Dimensions

unit: mm.

Type	DIMENSIONS				
	L	W	C	D	T
FPF03	1.60±0.10	0.80±0.10	0.30±0.20	0.30±0.20	0.45±0.10
FPF05	2.00±0.15	1.20±0.15	0.40±0.20	0.40±0.20	0.50±0.10
FPF06	3.10±0.15	1.60±0.15	0.50±0.25	0.50±0.25	0.55±0.10
FPF20	5.00±0.20	2.50±0.20	0.60±0.25	0.60±0.25	0.60±0.10
FPF25	6.30±0.20	3.10±0.20	0.60±0.25	1.80±0.25	0.60±0.15

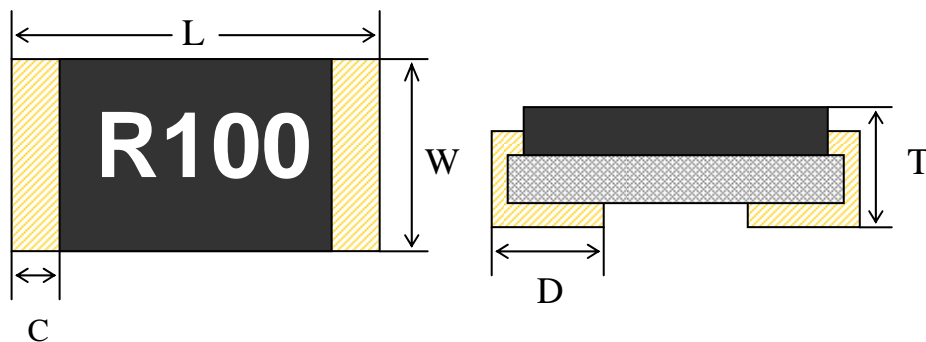

Recommended Solder Pad Dimensions

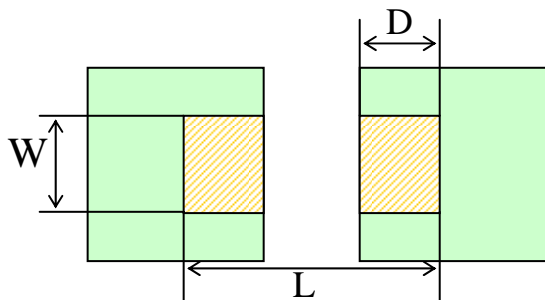

Type	W	D	L
FPF25	3.7mm	2.45mm	7.6mm



### 3. SPECIFICATION

#### Electrical Characteristic

Type	Size	Power Rating at 70	Max. RCWV	Max. Overload Voltage	Resistance Tolerance (%)	Temperature Coefficient (TCR; ppm/ )	Resistance Range ( )		Standard Resistance Values
							Min.	Max.	
FPF03	0603	1/4W	477mV	954mV	±1% ±5%	±200 ±150*	47m 100m	91m 910m	E-24
FPF05	0805	1/3W	551mV	1102mV		±200 ±100*	47m 100m	91m 910m	
FPF06	1206	1/2W	675mV	1349mV		±100* ±100	47m 100m	91m 910m	
FPF20	2010	1W	954mV	1908mV			47m 100m	91m 910m	
FPF25	2512	2W	1349mV	2698mV					

Note :

(\*)2W loading with total solder-pad and trace size of 300 mm<sup>2</sup>

(\*\*) E = (P×R)<sup>1/2</sup>

E : Working Voltage(V) , P : Rated Power(W) , R : Resistance Value( )

Resistance 47m~91m Temperature 25 ~-55 ,150ppm for 2512,2010, 200ppm for 1206

Resistance 100m~910m Temperature 25 ~-55 ,150ppm for 0805, 200ppm for 0603

#### Reliability Performance

Test Item	Specification	Test Method
DC Resistance	F : ±1% ; J : ±5%	IEC 60115-1 / JIS C 5201-1 , Clause 4.5 Measure the resistance Value.
Short Time Overload	J: R ±(2% + 0.5m ) F: R ±(1% + 0.5m )	5 × Rated power for 5 seconds
Solderability	Over 95% of termination must be covered with solder	IEC 60115-1 / JIS C 5201-1 , Clause 4.17 After immersing flux, dip in the 235±2 molten solder bath for 2±0.5 sec.
Resistance to solder Heat	J: R ±(1% + 0.5m ) F: R ±(0.5% + 0.5m ) No mechanical damage	IEC 60115-1 / JIS C 5201-1 , Clause 4.18 With 260±5 for 10±1sec.
Load Life Humidity	J: R ±(3% + 0.5m ) F: R ±(1% + 0.5m )	40±2 with relative humidity 90% ~ 95% D.C. rated voltage for 1.5 hours ON 30 minutes OFF.



Temperature Coefficient of Resistance (TCR)	Test temperature: -55~+155 Refer to T.C.R specification in page 7	IEC 60115-1 / JIS C 5201-1 , Clause 4.8  $\text{TCR}(\text{ppm}/^\circ\text{C}) = \frac{R_2 - R_1}{R_1 \times 1} / (T_2 - T_1) \times 10^6$ Test temperature : $\begin{matrix} T_1 & T_2 \\ 25 & \sim -55 \\ 25 & \sim +155 \end{matrix}$
Load Life	J : R $\pm(3\% + 0.5m)$ F : R $\pm(1\% + 0.5m)$	IEC 60115-1 / JIS C 5201-1 , Clause 4.25 Rated voltage for 1.5 hours for followed by a pause 0.5 hour at $70 \pm 3$ . Cycle repeated 1000 hours
Temperature Cycle	J : R $\pm(1\% + 1m)$ F : R $\pm(0.5\% + 1m)$ No mechanical damage	IEC 60115-1 / JIS C 5201-1 , Clause 4.19 Repeat 5 cycles as follows -55 (30min.) + 25 (2~3min.) + 155 (30min.) + 25 (2~3min.)
Insulation Resistance	Between termination and coating must be over 1000M	IEC 60115-1 / JIS C 5201-1 , Clause 4.6 Test voltage : $100 \pm 15V$
Bending strength	J : R $\pm(1\% + 1m)$ F : R $\pm(0.5\% + 1m)$ No mechanical damage	IEC 60115-1 / JIS C 5201-1 , Clause 4.33 Resistance change after bended on the 90mm PCB. Bending width : 3mm for 0603 0805 2mm for 1206 2010 2512

4. PACKAGING

Peel Strength of Top Cover Tape

The peel speed shall be about 300 mm/min

The peel force of top cover tape shall between 0.1 to 0.7N

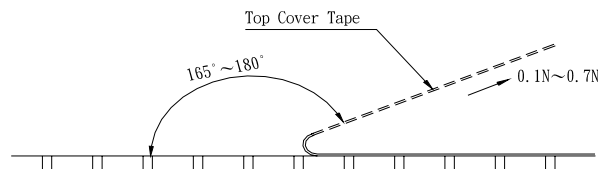



4.2 Tape Packaging Dimensions

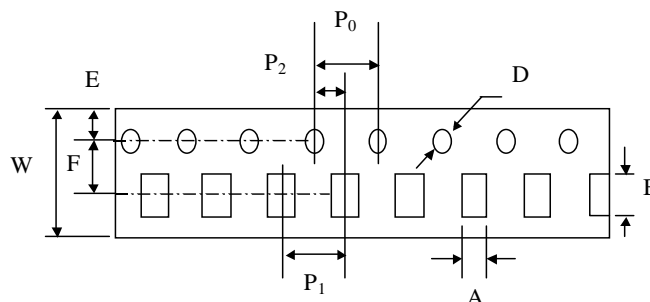

Accumulated dimensional tolerance  $40\pm 0.2\text{mm}$

Size	A	B	W	F	E	P1	P2	P0	D
0603	$1.10\pm 0.20$	$1.90\pm 0.20$	$8.00\pm 0.30$	$3.50\pm 0.05$	$1.75\pm 0.10$	$4.00\pm 0.10$	$2.00\pm 0.05$	$4.00\pm 0.10$	$1.50+0.10/-0$
0805	$1.65\pm 0.20$	$2.40\pm 0.20$	$8.00\pm 0.30$	$3.50\pm 0.05$	$1.75\pm 0.10$	$4.00\pm 0.10$	$2.00\pm 0.05$	$4.00\pm 0.10$	$1.50+0.10/-0$
1206	$2.00\pm 0.20$	$3.60\pm 0.20$	$8.00\pm 0.30$	$3.50\pm 0.05$	$1.75\pm 0.10$	$4.00\pm 0.10$	$2.00\pm 0.05$	$4.00\pm 0.10$	$1.50+0.10/-0$
2010	$2.80\pm 0.20$	$5.50\pm 0.20$	$12.00\pm 0.30$	$5.50\pm 0.05$	$1.75\pm 0.10$	$4.00\pm 0.10$	$2.00\pm 0.05$	$4.00\pm 0.10$	$1.50+0.10/-0$
2512	$3.50\pm 0.20$	$6.70\pm 0.20$	$12.00\pm 0.30$	$5.50\pm 0.05$	$1.75\pm 0.10$	$4.00\pm 0.10$	$2.00\pm 0.05$	$4.00\pm 0.10$	$1.50+0.10/-0$

unit : mm

4.3 Reel Dimensions

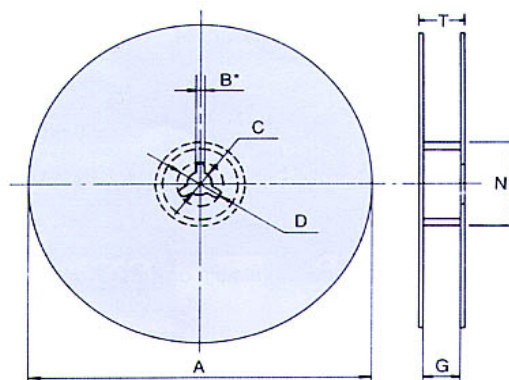

Size	Packaging Q'ty	A	N	C	D	B	G	T
0603	5kpcs/Reel	$178.0\pm 2.0$	$60.0\pm 0.5$	$13.0\pm 0.5$	20(Min.)	$2.0\pm 0.5$	$10.0\pm 1.5$	14.9max.
0805	10kpcs/Reel	$254.0\pm 2.0$	$100.0\pm 1.0$	$13.5\pm 0.5$	20(Min.)	$2.0\pm 0.5$	$10.0\pm 1.5$	14.9max.
1206	20kpcs/Reel	$330.0\pm 2.0$	$100.0\pm 1.0$	$13.5\pm 0.5$	20(Min.)	$2.0\pm 0.5$	$10.0\pm 1.5$	14.9max.
2010 2512	4kpcs/Reel	$178.0\pm 2.0$	$60.0\pm 0.5$	$13.0\pm 0.5$	20(Min.)	$2.0\pm 0.5$	$13.8\pm 1.5$	16.7max.
	8kpcs/Reel	$254.0\pm 2.0$	$100.0\pm 1.0$	$13.0\pm 0.5$	20(Min.)	$2.0\pm 0.5$	$13.8\pm 1.5$	20.0max.
	16kpcs/Reel	$330.0\pm 2.0$	$100.0\pm 1.0$	$13.5\pm 0.5$	20(Min.)	$2.0\pm 0.5$	$13.8\pm 1.5$	20.0max.

unit : mm

All product specification and data are subject to change without notice