

**TZV SERIES**

105°C Low Impedance, Lead Free Reflow Soldering.

◆ **FEATURES**

- Load Life : 105°C 2000 hours.
- Lead free reflow soldering is available.
- Available for high density mounting.
- Low impedance at 100kHz with selected materials.
- RoHS compliance.



◆ **SPECIFICATIONS**

Items	Characteristics																																
Category Temperature Range	-55~+105°C																																
Rated Voltage Range	6.3~50V.DC																																
Capacitance Tolerance	±20% (20°C, 120Hz)																																
Leakage Current(MAX)	I=0.01CV or 3 μA whichever is greater. (After 2 minutes application of rated voltage) I=Leakage Current(μA)    C=Rated Capacitance(μF)    V=Rated Voltage(V)																																
(tanδ) Dissipation Factor(MAX)	<table border="1"> <tr> <td>Rated Voltage (V)</td> <td>6.3</td> <td>10</td> <td>16</td> <td>25</td> <td>35</td> <td>50</td> <td>(20°C, 120Hz)</td> </tr> <tr> <td>tan δ</td> <td>0.26</td> <td>0.19</td> <td>0.16</td> <td>0.14</td> <td>0.12</td> <td>0.10</td> <td></td> </tr> </table>	Rated Voltage (V)	6.3	10	16	25	35	50	(20°C, 120Hz)	tan δ	0.26	0.19	0.16	0.14	0.12	0.10																	
Rated Voltage (V)	6.3	10	16	25	35	50	(20°C, 120Hz)																										
tan δ	0.26	0.19	0.16	0.14	0.12	0.10																											
Endurance	<p>After applying rated voltage with rated ripple current for 2000 hrs at 105°C , the capacitors shall meet the following requirements.</p> <table border="1"> <tr> <td>Capacitance Change</td> <td>Within ±30% of the initial value.</td> </tr> <tr> <td>Dissipation Factor</td> <td>Not more than 200% of the specified value.</td> </tr> <tr> <td>Leakage Current</td> <td>Not more than the specified value.</td> </tr> </table>	Capacitance Change	Within ±30% of the initial value.	Dissipation Factor	Not more than 200% of the specified value.	Leakage Current	Not more than the specified value.																										
Capacitance Change	Within ±30% of the initial value.																																
Dissipation Factor	Not more than 200% of the specified value.																																
Leakage Current	Not more than the specified value.																																
Low Temperature Stability Impedance Ratio(MAX)	<table border="1"> <tr> <td>Rated Voltage(V)</td> <td>6.3</td> <td>10</td> <td>16</td> <td>25</td> <td>35</td> <td>50</td> <td>(120Hz)</td> </tr> <tr> <td>Z(-25°C)/Z(20°C)</td> <td>2</td> <td>2</td> <td>2</td> <td>2</td> <td>2</td> <td>2</td> <td></td> </tr> <tr> <td>Z(-40°C)/Z(20°C)</td> <td>3</td> <td>3</td> <td>3</td> <td>3</td> <td>3</td> <td>3</td> <td></td> </tr> <tr> <td>Z(-55°C)/Z(20°C)</td> <td>4</td> <td>4</td> <td>4</td> <td>3</td> <td>3</td> <td>3</td> <td></td> </tr> </table>	Rated Voltage(V)	6.3	10	16	25	35	50	(120Hz)	Z(-25°C)/Z(20°C)	2	2	2	2	2	2		Z(-40°C)/Z(20°C)	3	3	3	3	3	3		Z(-55°C)/Z(20°C)	4	4	4	3	3	3	
Rated Voltage(V)	6.3	10	16	25	35	50	(120Hz)																										
Z(-25°C)/Z(20°C)	2	2	2	2	2	2																											
Z(-40°C)/Z(20°C)	3	3	3	3	3	3																											
Z(-55°C)/Z(20°C)	4	4	4	3	3	3																											

◆ **MULTIPLIER FOR RIPPLE CURRENT**

Frequency coefficient

Frequency (Hz)		120	1k	10k	100k ≤
Coefficient	4.7 μF	0.42	0.60	0.80	1.00
	10~33 μF	0.45	0.75	0.90	1.00
	47~100 μF	0.50	0.80	0.95	1.00
	220~1000 μF	0.60	0.85	0.95	1.00

◆ **MARKING**

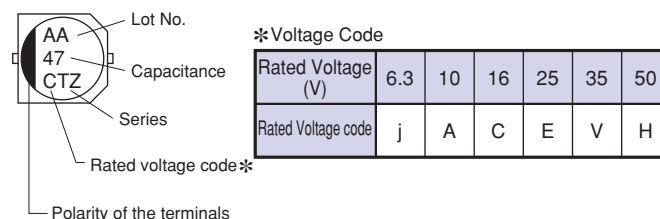

◆ **PART NUMBER**

□□□    TZV    □□□□□    □    □□□    □□    DxL  
 Rated Voltage    Series    Rated Capacitance    Capacitance Tolerance    Option    Lead Forming    Case Size

◆ DIMENSIONS

(mm)

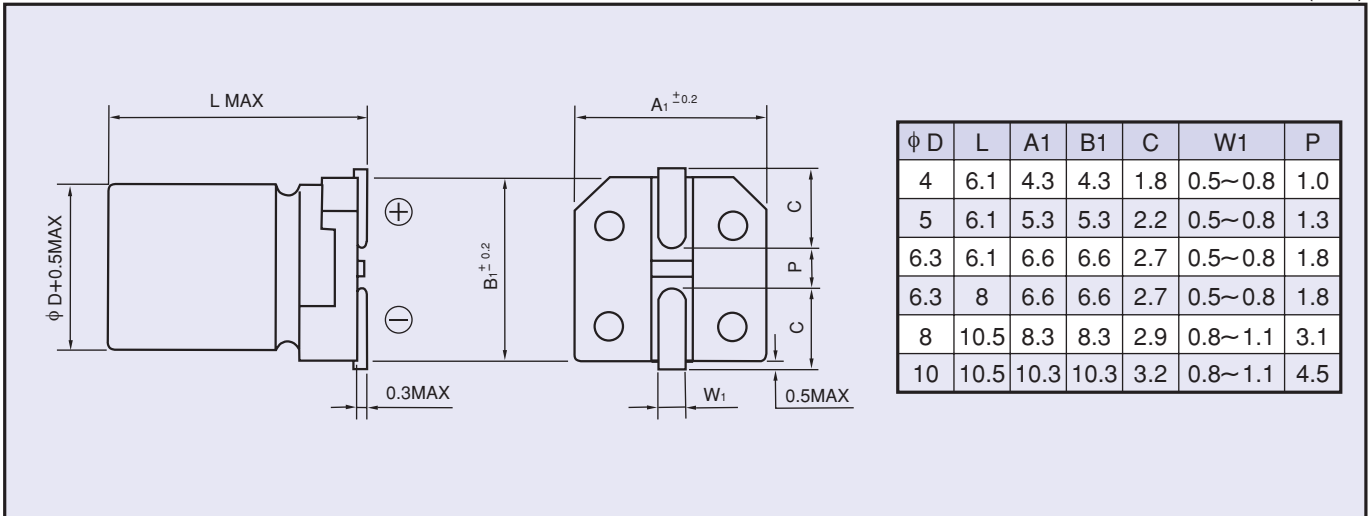

◆ STANDARD SIZE

Size φ D×L(mm), Ripple Current (mA r.m.s./105°C, 100kHz), Impedance(Ω MAX/20°C, 100kHz)

WV (V.DC) Cap(μF)	6.3 (0J)			10 (1A)			16 (1C)		
	Size	Ripple	Z	Size	Ripple	Z	Size	Ripple	Z
10							4×6.1	90	1.35
22	4×6.1	90	1.35				4×6.1	90	1.35
							5×6.1	170	0.70
33				4×6.1	90	1.35	5×6.1	170	0.70
47	4×6.1	90	1.35				5×6.1	170	0.70
	5×6.1	170	0.70				6.3×6.1	250	0.36
100	5×6.1	170	0.70				6.3×6.1	250	0.36
	6.3×6.1	250	0.36				6.3×8	300	0.34
220	6.3×6.1	250	0.36	6.3×8	300	0.34	6.3×8	300	0.34
	6.3×8	300	0.34						
330	6.3×8	300	0.34				8×10.5	600	0.16
470				8×10.5	600	0.16	8×10.5	600	0.16
680				8×10.5	600	0.16	10×10.5	850	0.08
1000	8×10.5	600	0.16	10×10.5	850	0.08			

WV (V.DC) Cap(μF)	25 (1E)			35 (1V)			50 (1H)		
	Size	Ripple	Z	Size	Ripple	Z	Size	Ripple	Z
4.7				4×6.1	90	1.45	4×6.1	60	2.90
10				4×6.1	90	1.45	5×6.1	85	1.52
				5×6.1	170	0.70	6.3×6.1	165	0.88
22				5×6.1	170	0.70	6.3×6.1	165	0.88
				6.3×6.1	250	0.36			
33	5×6.1	170	0.70	6.3×6.1	250	0.36	6.3×8	195	0.68
	6.3×6.1	250	0.36						
47	6.3×6.1	250	0.36	6.3×6.1	250	0.36	6.3×8	195	0.68
				6.3×8	300	0.34			
				6.3×8	300	0.34			
100	6.3×8	300	0.34	8×10.5	600	0.16	8×10.5	350	0.34
				8×10.5	600	0.16			
220	8×10.5	600	0.16	8×10.5	600	0.16	10×10.5	670	0.18
330	8×10.5	600	0.16	10×10.5	850	0.09			
470	10×10.5	850	0.09						