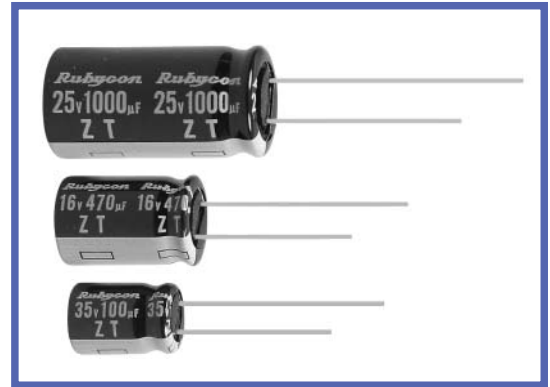

ZT SERIES
Load Life: 125°C 1000~4000hours. Low impedance.
◆FEATURES

- Low impedance at 100kHz with selected materials.
- Load Life : 125°C 1000~4000hours.
- RoHS compliance.

◆SPECIFICATIONS

Items	Characteristics																				
Category Temperature Range	-40~+125°C																				
Rated Voltage Range	10~35V.DC																				
Capacitance Tolerance	±20% (20°C, 120Hz)																				
Leakage Current(MAX)	I=0.03CV or 3 µA whichever is greater. (After 2 minutes) I=Leakage Current(µA) C=Rated Capacitance(µF) V=Rated Voltage(V)																				
(tanδ) Dissipation Factor(MAX)	<table border="1"> <thead> <tr> <th>Rated Voltage (V)</th> <th>10</th> <th>16</th> <th>25</th> <th>35</th> </tr> </thead> <tbody> <tr> <td>tan δ</td> <td>0.20</td> <td>0.16</td> <td>0.14</td> <td>0.12</td> </tr> </tbody> </table> (20°C, 120Hz) When nominal capacitance is over 1000 µF, tanδ shall be added 0.02 to the listed value with increase of every 1000 µF.	Rated Voltage (V)	10	16	25	35	tan δ	0.20	0.16	0.14	0.12										
Rated Voltage (V)	10	16	25	35																	
tan δ	0.20	0.16	0.14	0.12																	
Endurance	After life test with rated ripple current at conditions stated in the table below, the capacitors shall meet the following requirements. <table border="1"> <thead> <tr> <th>Capacitance Change</th> <th>Within ±30% of the initial value.</th> <th>Case Size</th> <th>Life Time (hrs)</th> </tr> </thead> <tbody> <tr> <td>Dissipation Factor</td> <td>Not more than 300% of the specified value.</td> <td>φ D ≤ 6.3</td> <td>1000</td> </tr> <tr> <td>Leakage Current</td> <td>Not more than the specified value.</td> <td>φ D = 8</td> <td>2000</td> </tr> <tr> <td></td> <td></td> <td>φ D = 10</td> <td>3000</td> </tr> <tr> <td></td> <td></td> <td>φ D = 12.5</td> <td>4000</td> </tr> </tbody> </table>	Capacitance Change	Within ±30% of the initial value.	Case Size	Life Time (hrs)	Dissipation Factor	Not more than 300% of the specified value.	φ D ≤ 6.3	1000	Leakage Current	Not more than the specified value.	φ D = 8	2000			φ D = 10	3000			φ D = 12.5	4000
Capacitance Change	Within ±30% of the initial value.	Case Size	Life Time (hrs)																		
Dissipation Factor	Not more than 300% of the specified value.	φ D ≤ 6.3	1000																		
Leakage Current	Not more than the specified value.	φ D = 8	2000																		
		φ D = 10	3000																		
		φ D = 12.5	4000																		
Low Temperature Stability Impedance Ratio(MAX)	<table border="1"> <thead> <tr> <th>Rated Voltage (V)</th> <th>10</th> <th>16</th> <th>25</th> <th>35</th> </tr> </thead> <tbody> <tr> <td>Z(-25°C)/Z(20°C)</td> <td>3</td> <td>2</td> <td>2</td> <td>2</td> </tr> <tr> <td>Z(-40°C)/Z(20°C)</td> <td>6</td> <td>4</td> <td>3</td> <td>3</td> </tr> </tbody> </table> (120Hz)	Rated Voltage (V)	10	16	25	35	Z(-25°C)/Z(20°C)	3	2	2	2	Z(-40°C)/Z(20°C)	6	4	3	3					
Rated Voltage (V)	10	16	25	35																	
Z(-25°C)/Z(20°C)	3	2	2	2																	
Z(-40°C)/Z(20°C)	6	4	3	3																	

◆MULTIPLIER FOR RIPPLE CURRENT

Frequency coefficient

Frequency (Hz)		120	1k	10k	100k ≤
Coefficient	22~33 µF	0.20	0.50	0.80	1.00
	39~100 µF	0.25	0.60	0.90	1.00
	120~270 µF	0.35	0.70	0.92	1.00
	330~680 µF	0.45	0.75	0.95	1.00
	820~1800 µF	0.50	0.80	0.96	1.00
	2200 µF	0.55	0.85	0.98	1.00

◆DIMENSIONS

(mm)

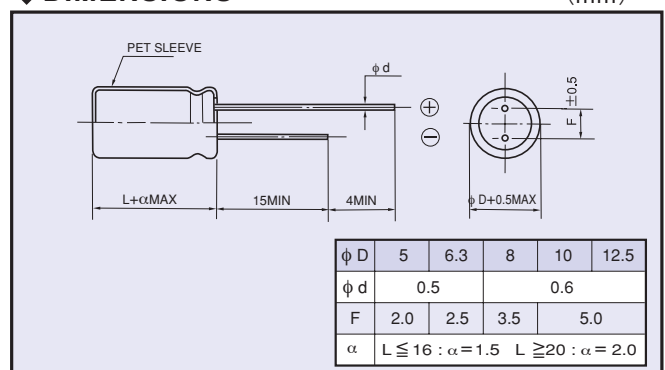
◆PART NUMBER

□□□	ZT	□□□□□	□	□□□	□□	DxL
Rated Voltage	Series	Rated Capacitance	Capacitance Tolerance	Option	Lead Forming	Case Size

◆STANDARD SIZE

Rated Voltage (V·DC)	Rated capacitance (μF)	Size φ D×L(mm)	Rated ripple current (mA r.m.s./105°C, 100kHz)	Impedance(ΩMAX)	
				20°C, 100kHz	-10°C, 100kHz
10 (1A)	56	5×11	250	0.40	1.3
	120	6.3×11	405	0.17	0.53
	330	8×11.5	760	0.094	0.29
	470	8×16	995	0.073	0.23
	680	8×20	1250	0.054	0.17
	470	10×12.5	1030	0.069	0.21
	680	10×16	1430	0.050	0.16
	1000	10×20	1500	0.030	0.090
	1200	10×23	1620	0.029	0.086
	1500	12.5×20	1720	0.028	0.069
	2200	12.5×25	1900	0.024	0.059
16 (1C)	47	5×11	250	0.40	1.3
	100	6.3×11	405	0.17	0.53
	220	8×11.5	760	0.094	0.29
	330	8×16	995	0.073	0.23
	470	8×20	1250	0.054	0.17
	330	10×12.5	1030	0.069	0.21
	470	10×16	1430	0.050	0.16
	680	10×20	1500	0.030	0.090
	820	10×23	1620	0.029	0.086
	1000	12.5×20	1720	0.028	0.069
	1500	12.5×25	1900	0.024	0.059
25 (1E)	33	5×11	250	0.40	1.3
	56	6.3×11	405	0.17	0.53
	150	8×11.5	760	0.094	0.29
	220	8×16	995	0.073	0.23
	270	8×20	1250	0.054	0.17
	220	10×12.5	1030	0.069	0.21
	330	10×16	1430	0.050	0.16
	470	10×20	1500	0.030	0.090
	560	10×23	1620	0.029	0.086
	680	12.5×20	1720	0.028	0.069
	1000	12.5×25	1900	0.024	0.059
35 (1V)	22	5×11	250	0.40	1.3
	56	6.3×11	405	0.17	0.53
	100	8×11.5	760	0.094	0.29
	120	8×16	995	0.073	0.23
	180	8×20	1250	0.054	0.17
	150	10×12.5	1030	0.069	0.21
	220	10×16	1430	0.050	0.16
	270	10×20	1500	0.030	0.090
	330	10×23	1620	0.029	0.086
	470	12.5×20	1720	0.028	0.069
	560	12.5×25	1900	0.024	0.059